



EUROGARD Roller Shutters

Euro Transport Manufacturing Ltd - Euroguard roller shutters are manufactured from high specification materials and each item is a precision made-to-measure unit. Attention to the following procedure will ensure correct operation of the product.

IMPORTANT:- THE SPRING BARREL/SHAFT ASSEMBLY OF ALL EUROGARD ROLLER SHUTTERS ARE SUPPLIED PRE-TENSIONED. ADJUSTMENT OF THE SPRINGING, THEREFORE CAN BE DANGEROUS AND SHOULD BE UNDERTAKEN ONLY BY PERSONNEL WHO HAVE PREVIOUS EXPERIENCE OF THIS OPERATION

Fitting Instructions

1. Before proceeding, check that the dimensions stated on the advice note/shutter packaging are exactly the same as the submitted order. Any variation must be reported before attempting to install the shutter. Check the size of the opening against the dimensions given on the advice note/shutter packaging, also check that the opening is square by measuring diagonally across corners of the opening.

Fit channels and brackets into the aperture, ensuring that the channels are both vertical and parallel. Brackets must be horizontal and parallel and must be 'tied back' to the vehicle body.

NOTE: THE BRACKETS CONTAIN A SWINGING ARM, FREEDOM OF MOVEMENT OF THIS ARM MUST BE MAINTAINED FOR SATISFACTORY OPERATION OF THE SHUTTER.

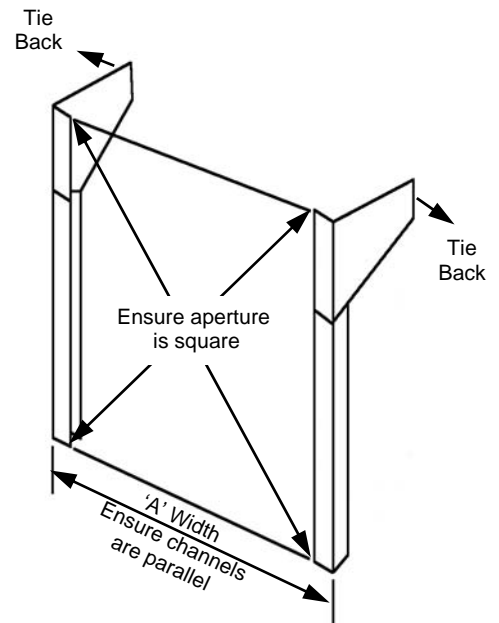

2. Remove spring assembly from the curtain by firstly unrolling the curtain, making sure that the surface on which the curtain is being unrolled is free from anything which may damage the curtain face. (DO NOT STAND ON THE CURTAIN). Separate the curtain from the spring assembly by disconnecting the split pins. The spring assembly should now be located/secured into the brackets with the bolts provided. The barrel end with the charge pin must be fitted at the right hand side of the shutter when viewing from the inside of the curtain i.e. inside the vehicle. **DO NOT** at this stage attempt to remove the spring assembly charge pins. Check again for free movement of the swinging arm bracket.

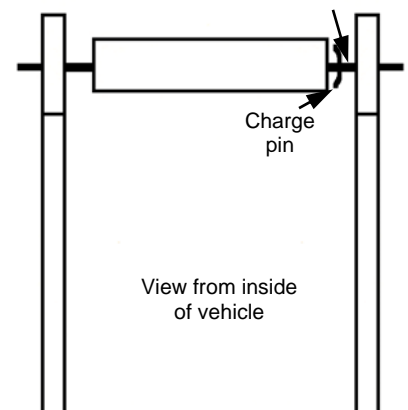

- Remove the bottom bar stops (if fitted). Enter curtain, bottom rail first, over the spring assembly into the channels and then fit the bottom bar stops. Re-connect curtain to spring assembly unit using split pins provided, check for free movement of the swinging arm bracket and ensure that the curtain is centrally positioned within the opening.

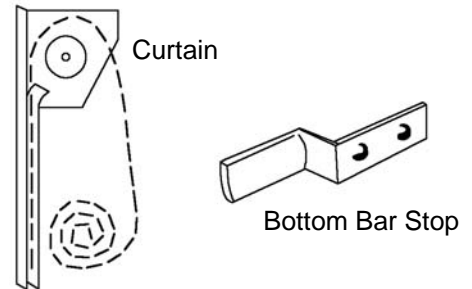

- Remove charge pins from spring assembly. The shutter should now be operational.

BARREL SPRINGING/HELICAL TYPE



SHOULD ANY FINE ADJUSTMENT BE NECESSARY, PLEASE NOTE THE FOLLOWING:

BARREL SPRINGING/HELICAL TYPE

- With the shutter in the down position, remove the bottom bar stops from the bottom rail.
- Slowly move the shutter to the up position holding the bottom rail firmly. **DO NOT LET GO OF THE CURTAIN DURING THIS OPERATION.** Check that there are no obstructions to prevent the rolled up curtain freely revolving around the shaft but **DO NOT** let go of the curtain.
- Tension can now be either added to or taken off the spring barrel by rotating the rolled up curtain in a clockwise or anti-clockwise direction.
- After adjustment feed the bottom rail carefully into the side channels and take the shutter to the closed position. Hold the shutter in this position whilst you -re-fit the bottom bar stops. The shutter should now be operational. If any further adjustment is necessary repeat the procedure.

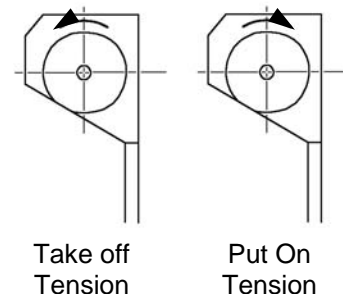
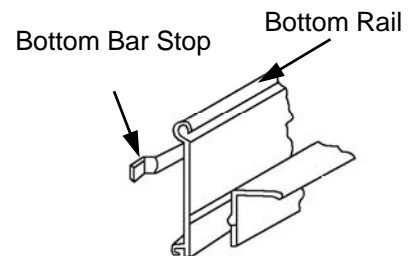
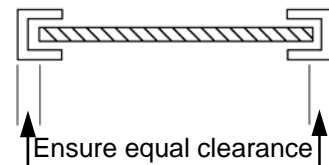

IMPORTANT NOTES.

BOTTOM BAR STOPS AND LOCKING HANDLE (IF APPLICABLE) ARE LOOSE ITEMS AND ARE PACKED SEPERATELY
CHANNELS AND MOVING PARTS SHOULD BE CLEANED REGULARLY AND LUBRICATED WITH WD40 LUBRICANT (NOT GREASE)